



# Background Document for Floor Vibrations



## Table of Content

Summary .....	2
1. Design Considerations .....	3
1.1. Loadings .....	3
1.2. Perception and perception classes.....	3
1.3. Evaluation .....	5
2. OS-RMS Method.....	7
2.1. Introduction.....	7
2.2. Transfer function method .....	8
2.3. The one step root mean square value .....	8
2.3.1. Standard walking load .....	9
2.3.2. Weighting .....	10
2.4. Obtaining the OS-RMS <sub>90</sub> value.....	10
2.5. Hand calculation method .....	11
3. Alternative analysis methods .....	12
3.1. Modal superposition .....	12
3.1.1. Steady-state response.....	12
3.1.2. Transient response.....	13
3.1.3. Weighting factors.....	13
3.1.4. Contour plots .....	13
3.1.5. Detailed procedure.....	14
3.2. Other vibration considerations.....	14
3.3. Simplified approach .....	14
4. Improving structures.....	15
4.1. Increasing the modal mass.....	15
4.2. Adjusting the frequency .....	16
4.3. Increasing the damping.....	16
4.4. Structural means.....	16
4.5. Retrofit measures.....	16
5. References .....	18

## Summary

This document provides background information to "Vibration Design of Floors – Guideline". It presents alternative and more general ways for the determination of the floor response to dynamic human induced forces.

The theoretical methods presented here and in the guideline document have been elaborated/investigated in the RFCS-Project "Vibration of Floors". The guideline and background document are here disseminated under the grant of the Research fund for Coal and Steel within the project "HIVOSS".

## 1. Design Considerations

### 1.1. Loadings

The mass present in the structure has a very significant effect on both the frequency of the floor plate and the magnitude of the vibrations. It is therefore important that the distributed mass used in vibration analysis is representative of the mass that will be present in service, as a higher mass will reduce the magnitude of the floor vibration at a given frequency. In design, the mass per unit area should be taken as the unfactored self-weight of the structure including superimposed dead loads such as the weight of ceilings and services. In addition, where the designer can be confident that such loading will be guaranteed to exist in the finished structure, an additional allowance may be included for semi-permanent loads. Generally it is recommended that this allowance should not exceed 10% of the nominal imposed load. Generally the mass of people present on the floor is not explicitly considered, but in the case of very light structures this additional mass is very significant and can be considered.

### 1.2. Perception and perception classes

In a similar way to human hearing, the human perception of vibration varies with frequency – human ears cannot detect low frequency or high frequency sounds, and similarly the human body cannot detect very high frequency vibration. To attenuate a vibration response to take account of this response, frequency-dependent weighting factors are used. The level of vibration that can be perceived also depends on the direction of incidence to the human body, and for this the basicentric coordinate system shown in Figure 1.1 is used (the z-axis corresponds to the direction of the human spine). The threshold of perception (the vibration level under which the average human will not be able to perceive any motion) is higher for z-axis vibration than for x- or y-axis vibration, indicating that x- or y-axis vibration is more easily perceived.

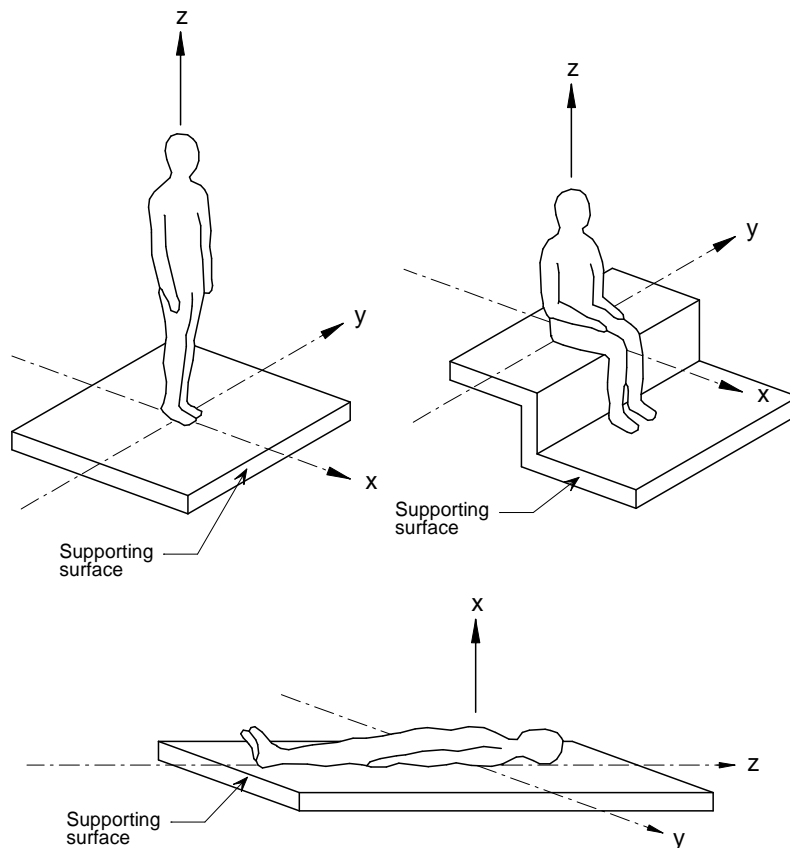

**Figure 1.1 Directions for Vibration defined in ISO 10137**

Values of frequency weighting are given in Standards such as ISO 10137[4]. Various weighting curves are given, depending on the direction of vibration and the activity. The weighting curves are also specific to the parameter being considered – velocity or acceleration. In most cases, the aim of vibration analysis is to reduce or remove discomfort, but in special circumstances, such as operating theatres, the level of vibration will need to be such that it cannot be perceived and does not affect the steadiness of hand or vision. Perception and discomfort use the same weightings but typically perception will have a lower allowable threshold (i.e. a subject can detect vibration without being discomforted by it), while there are different weighting curves for considering hand and vision control. The weighting curves for perception in both the z-axis ( $W_b$ ) and x- and y-axis directions ( $W_d$ ) are shown in Figure 1.2.

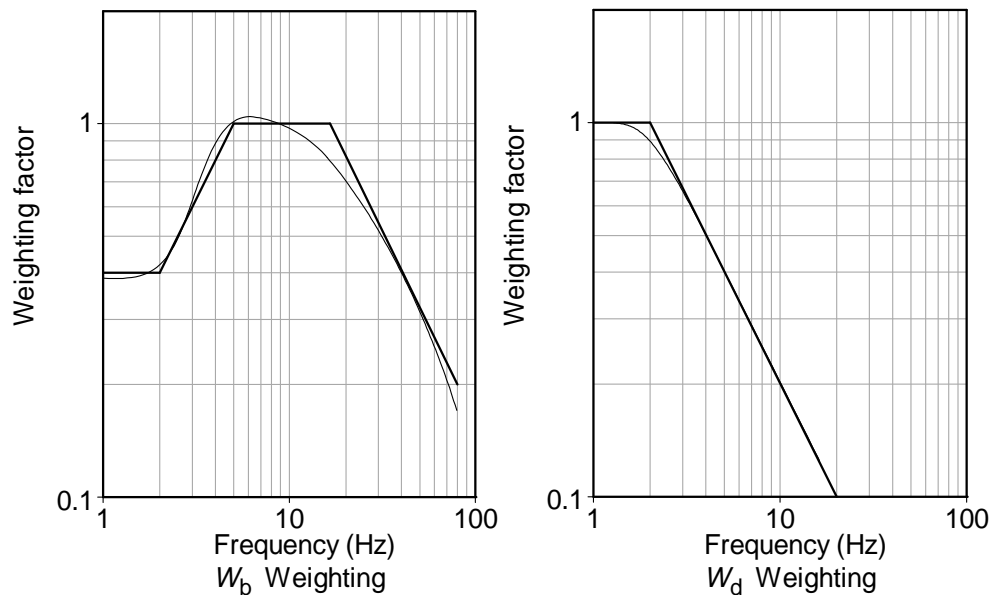
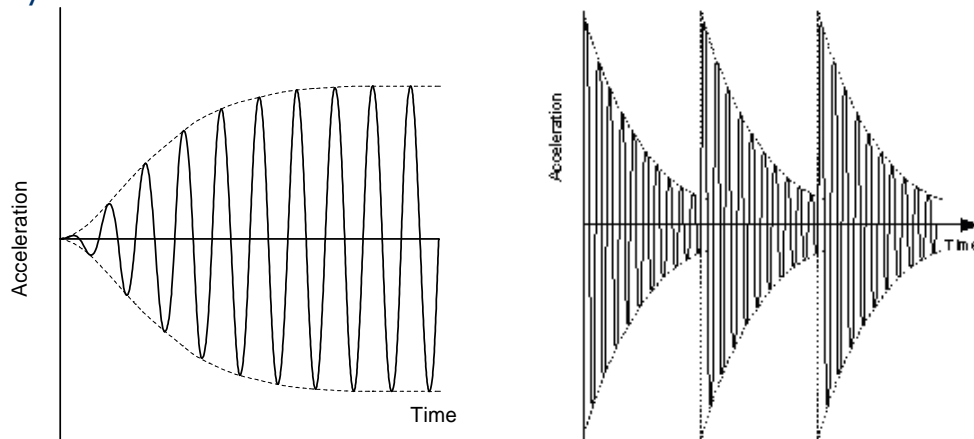

**Figure 1.2  $W_b$  and  $W_d$  frequency-acceleration weighting curves**

To illustrate the use of the curves, for z-axis vibration using curve  $W_b$  for discomfort, a sine wave of 8 Hz has the same feel as a sine wave at 2.5 Hz or 32 Hz with double the amplitude.

### 1.3. Evaluation

The response of a system to regular excitation will take the form of one of the plots shown in Figure 1.3, dependent on the comparison between the excitation frequency and the natural frequency of the system.



**Figure 1.3 Response Envelopes**

When the frequency of the excitation (or higher harmonics of the excitation) is similar to the natural frequency of the floor, the resulting response takes the form as shown on the left of Figure 1.3 – a gradual build up of the response envelope from zero to a steady-state level. This response is known as either a resonant response (because the floor is resonating with the excitation) or a steady-state response. For excitation from walking activities, this

kind of response typically occurs for floors with a fundamental natural frequency less than 9-10 Hz.

When the frequency of excitation is significantly lower than the natural frequency of the floor, the response envelope shown on the right of Figure 1.3 is typical, known as a transient response. In this case the floor plate responds to the excitation as if it is a series of impulses, with the vibration from one footstep dying away before the next footstep. These excitation types can be seen on the OS-RMS<sub>90</sub> plots as the contour lines become less dependent on the specific frequency as the floor frequency rises above 9 Hz, showing that the response is moving from a steady-state response to a transient response.

## 2.OS-RMS Method

### 2.1. Introduction

The one-step root mean square (OS-RMS) method is based on the findings of a research project funded by the ECSC on floor vibrations, see [1]. This chapter describes briefly the OS-RMS method which underlies the design check procedure.

The OS-RMS value represents the response of a floor which is brought into vibration due to a person walking on that floor. It is obtained from measured or simulated floor characteristics and a standard walking load function for a person with given weight and walking pace.

In calculating the OS-RMS value, the excitation point and response points do not necessarily have to coincide. Further, it is assumed that the excitation point is kept fixed, that is, the walking path is not taken into consideration. In general the excitation and response points are selected where the greatest vibration amplitudes are expected (in regular floors this is usually the middle of the floor span).

In the design check the 90 percentile of OS-RMS values obtained for different persons' weights and walking speeds (or step frequency) must be calculated. The 90 percentile is referred to as the OS-RMS<sub>90</sub> value and should subsequently be checked against the recommended values in Table 1 of the guideline.

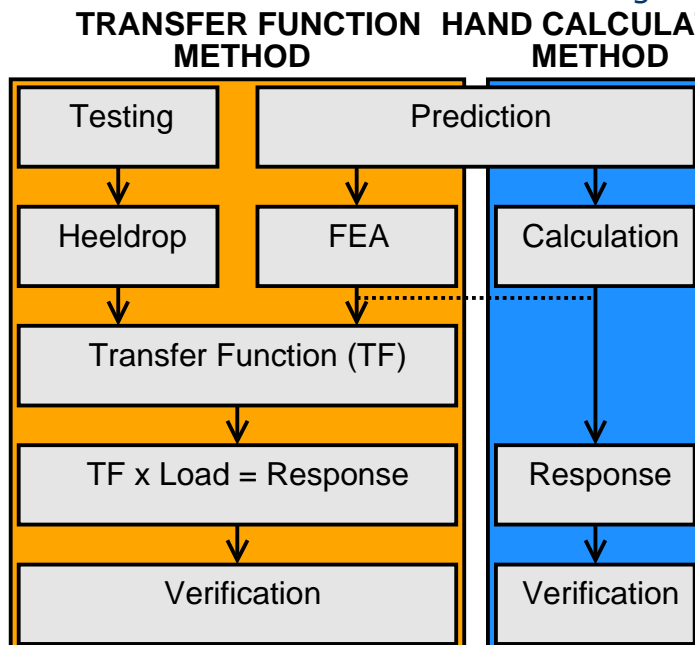

**Figure 2.1:** Simplified overview of design check using the OS-RMS method.

A single OS-RMS value for a given step frequency and person's weight can be obtained from one of the three following methods:

1. Hand calculation method
2. Transfer function method using measurements
3. Transfer function method using finite element analysis of the floor

The hand calculation method is the method which is covered by the guideline and is applicable to floors which can be easily described as a single degree of freedom mass-dashpot-spring system. Underlying the hand calculation method is the transfer function method. An overview of the design check procedure, comparing the three methods is given in Figure 2.1.

## 2.2. Transfer function method

In the transfer function method, the floor's characteristics are described in terms of a frequency response function, FRF, or transfer function. The transfer function represents the response of a structure when it is subjected to a harmonic load (a sinusoidal time varying load function) with a given frequency and amplitude equal to one.

When this function is used in combination with the standard walking load, the OS-RMS value can be determined.

The transfer function method can be applied where the floor response is obtained either by measurement or by finite element calculations.

The use of the transfer function method implies that the calculation of the response of the floor occurs in the frequency domain.

Alternatively, when using a finite element calculation, the response can be obtained in the time domain. This can be rather time consuming as the determination of the OS-RMS<sub>90</sub> value requires many response calculations.

## 2.3. The one step root mean square value

The OS-RMS value is obtained from the response of a floor to a standardized walking load. It is defined as the root mean square value over a given interval of the weighted velocity response at a point on the floor. The interval is selected starting from the highest peak in the response and either the previous or the next peak in the response, see Figure 2.2.

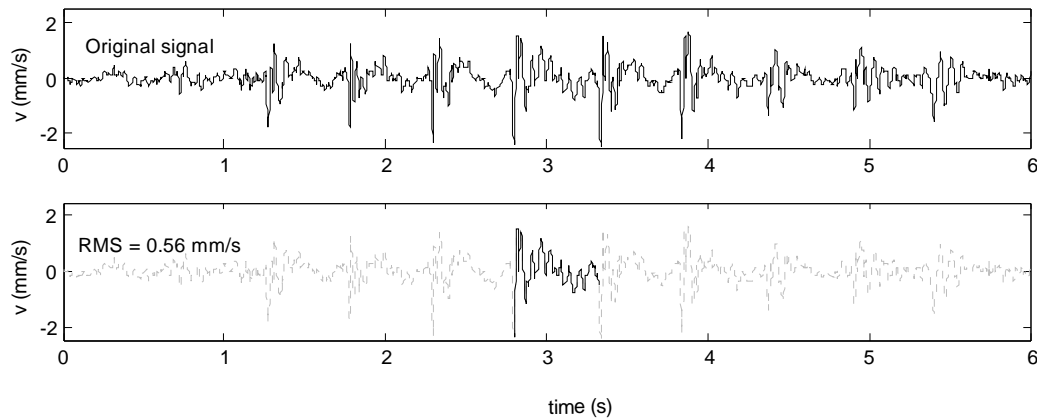

**Figure 2.2:** Selection of interval in weighted velocity response for calculation of the OS-RMS value.

Given this definition, the interval over which the OS-RMS value is obtained corresponds to the duration of a single step. This ensures a consistent measure for the vibration level<sup>1</sup>.

### 2.3.1. Standard walking load

The standard walking load is taken as a series of consecutive steps whereby each step (or footfall) load is described by a polynomial. The normalized step load is given by:

$$\frac{F(t)}{G} = K_1 t + K_2 t^2 + K_3 t^3 + K_4 t^4 + K_5 t^5 + K_6 t^6 + K_7 t^7 + K_8 t^8$$

where  $G$  is the person's mass. The coefficients  $K_1$  to  $K_8$  depend on the step frequency ( $f_s$ ) and are given in Table 2.1. The load duration,  $t_s$ , is given by the following formula:

$$t_s = 2.6606 - 1.757 \cdot f_s + 0.3844 \cdot f_s^2$$

For  $t > t_s$ ,  $F(t) = 0$ .

**Table 2.1: Coefficients  $K_1$  to  $K_8$  for given walking frequency ( $f_s$ )**

	$f_s \leq 1.75$	$1.75 < f_s < 2$	$f_s \geq 2$
$K_1$	$-8 \times f_s + 38$	$24 \times f_s - 18$	$75 \times f_s - 120.4$
$K_2$	$376 \times f_s - 844$	$-404 \times f_s + 521$	$-1720 \times f_s + 3153$
$K_3$	$-2804 \times f_s + 6025$	$4224 \times f_s - 6274$	$17055 \times f_s - 31936$
$K_4$	$6308 \times f_s - 16573$	$-29144 \times f_s + 45468$	$-94265 \times f_s + 175710$
$K_5$	$1732 \times f_s + 13619$	$109976 \times f_s - 175808$	$298940 \times f_s - 553736$
$K_6$	$-24648 \times f_s + 16045$	$-217424 \times f_s + 353403$	$-529390 \times f_s + 977335$
$K_7$	$31836 \times f_s - 33614$	$212776 \times f_s - 350259$	$481665 \times f_s - 888037$
$K_8$	$-12948 \times f_s + 15532$	$-81572 \times f_s + 135624$	$-174265 \times f_s + 321008$

The standard walking load function is built from the step load defined above, by adding the step load to this function repeatedly at

<sup>1</sup> OS-RMS values defined in this way can be unambiguously compared with each other. If on the other hand, a constant interval greater than the duration of a single step was used, then the rms value over this interval would depend on the step frequency and interval duration.

intervals of  $1/f_s$ . Examples of the standard step load and walking load functions are given in Figure 2-3.

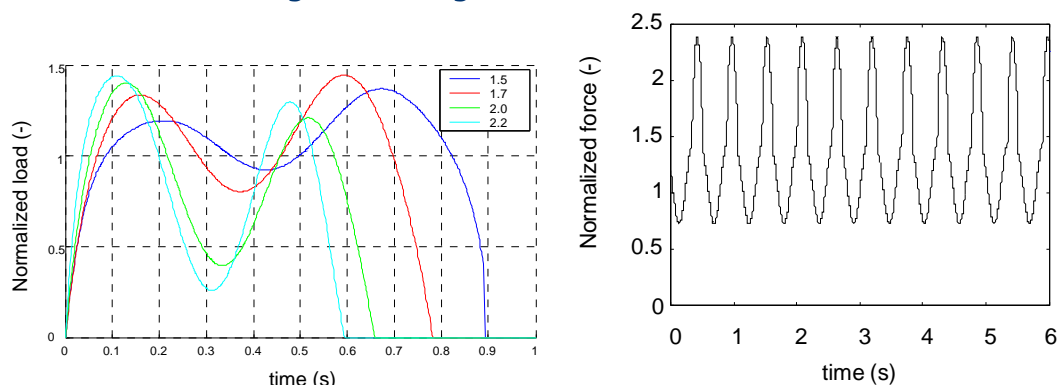

**Figure 2-3: Step load for four different step frequencies (left) and example of walking load function (right).**

### 2.3.2. Weighting

The OS-RMS value is determined from the weighted velocity response at a point on the floor. The weighted response is obtained by applying the following weighting function:

$$|H(f)| = \frac{1}{v_0} \frac{1}{\sqrt{1 + (f_0/f)^2}}$$

where  $f_0=5.6$  Hz and  $v_0$  is the reference velocity equal 1.0 mm/s. Because of division by a reference velocity, the weighted response is dimensionless.

### 2.4. Obtaining the OS-RMS<sub>90</sub> value

As stated previously, the final design checked is based on the OS-RMS<sub>90</sub> value. This value is obtained by calculating the OS-RMS for all possible combinations of persons' weights and walking paces defined in Table 2-2. According to these tables, a total of  $35 \times 20 = 700$  OS-RMS values corresponding to each possible combination must be calculated. From the relative frequency (probability) of each combination, the cumulative frequency of the OS-RMS value is obtained. The OS-RMS corresponding to a cumulative frequency of 90% defines the sought OS-RMS<sub>90</sub> value<sup>2</sup>.

**Table 2-2: Cumulative probability distribution function for persons' walking pace and persons' mass**

Cumulative probability	Step frequency $f_s$ (Hz)	Cumulative probability	Mass (kg)
0.0003	1.64	0.0000	30
0.0035	1.68	0.0002	35
0.0164	1.72	0.0011	40
0.0474	1.76	0.0043	45

<sup>2</sup> In effect, we are treating the OS-RMS value as a random variable and are seeking its 90% upper limit.

0.1016	1.80		0.0146	50
0.1776	1.84		0.0407	55
0.2691	1.88		0.0950	60
0.3679	1.92		0.1882	65
0.4663	1.96		0.3210	70
0.5585	2.00		0.4797	75
0.6410	2.04		0.6402	80
0.7122	2.08		0.7786	85
0.7719	2.12		0.8804	90
0.8209	2.16		0.9440	95
0.8604	2.20		0.9776	100
0.8919	2.24		0.9924	105
0.9167	2.28		0.9978	110
0.9360	2.32		0.9995	115
0.9510	2.36		0.9999	120
0.9625	2.40		1.0000	125
0.9714	2.44			
0.9782	2.48			
0.9834	2.52			
0.9873	2.56			
0.9903	2.60			
0.9926	2.64			
0.9944	2.68			
0.9957	2.72			
0.9967	2.76			
0.9975	2.80			
0.9981	2.84			
0.9985	2.88			
0.9988	2.92			
0.9991	2.96			
0.9993	3.00			

## 2.5. Hand calculation method

In the hand calculation method, the response calculation and subsequent statistical process to obtain the OS-RMS<sub>90</sub> value has been carried out beforehand. In this method, the structure is assumed to be a one degree of freedom system which is easily modelled using a mass-spring-dashpot. OS-RMS<sub>90</sub> values corresponding to various combinations of floor mass, stiffness and damping have been obtained and are presented in the graphs given in the guideline.

In this case it is sufficient to determine the modal parameters (mass, stiffness and damping) for the structure being investigated and then read off the corresponding OS-RMS<sub>90</sub> value from the graphs.

### 3. Alternative analysis methods

#### 3.1. Modal superposition

As an alternative to the transfer function and probability based design approach given by the OS-RMS approach, modal superposition techniques can also be used to determine the response of a floor to human induced vibration. This vibration can be caused by walking or by more lively activities such as aerobics or dancing. In this approach the floor is modelled in finite element software and the modal properties such as the frequencies, modal masses and mode shapes are extracted.

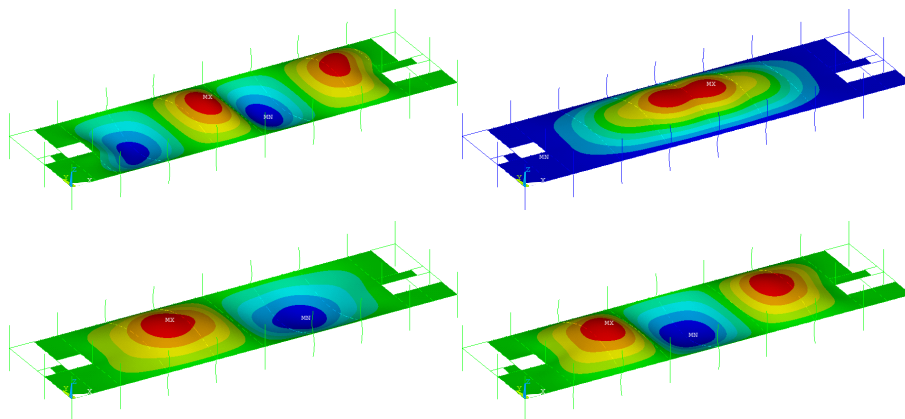

**Figure 3.1: Mode shapes for a typical floor**

Once the mode shapes have been extracted, a response analysis is performed to determine the accelerations of the floor. The input forces are determined by breaking the excitation forces down into frequency components using Fourier series. By using design values of the Fourier coefficients, the requirement to consider the variability of pacing frequency and body mass is removed, and a design acceleration can be calculated simply by analysing the worst-case pacing frequency.

The accelerations are calculated in two different ways, depending on whether a steady-state or transient response is expected.

##### 3.1.1. Steady-state response

For the steady-state or resonant case the accelerations are calculated using simple dynamic theory, where the acceleration of each mode from each harmonic of the excitation is equal to the ratio of the applied force to the modal mass, multiplied by a dynamic magnification factor (DMF). This DMF takes into account the amount of damping present in the structure and the ratio between the pacing frequency (or the harmonic that is being considered) and the modal frequency. At the worst case, the

harmonic of the pacing frequency equals the modal frequency, and the DMF is equal to  $1/2\zeta$ , where  $\zeta$  is the damping ratio. In typical floors  $\zeta = 3\%$ , and so the magnification factor is in the region of 17. The calculation also takes into account the magnitude of the mode shape at the excitation and response points that are being considered (which can either be coincident or separated). This means the effect of all the mode shapes that are being considered can be combined without over-estimating the vibration levels. Once the acceleration levels for each mode shape and excitation harmonic have been calculated, they are combined to produce a single root-mean-square acceleration that relates the excitation and response points.

### 3.1.2. Transient response

For the case of transient vibration, an impulse load is applied to each mode shape at the excitation point and the corresponding peak acceleration calculated by comparing this impulse load to the modal mass, the modal frequency and the mode shape. The decay of the acceleration is governed by the damping, and by summing the decaying vibration from each mode, the root-mean-square acceleration can be calculated.

### 3.1.3. Weighting factors

During the calculation of the acceleration, the weighting factors as shown in Figure 1.2 are taken into account to ensure that the acceleration calculated is relevant to human perception. The weighted acceleration can then be compared to limiting values such as those given in ISO 10137 or other Standards or guidance.

### 3.1.4. Contour plots

By performing this analysis for coincident excitation and response points all over the floor plate, the vibration performance of different areas of the floor can be established, as shown in Figure 3.2. This allows the architect or client to position vibration sensitive areas of a building layout (such as operating theatres, laboratories, etc.) in areas which are likely to have good vibration performance, and conversely to locate less sensitive areas (such as workshops, canteens, etc.) in the more lively areas of the floor.

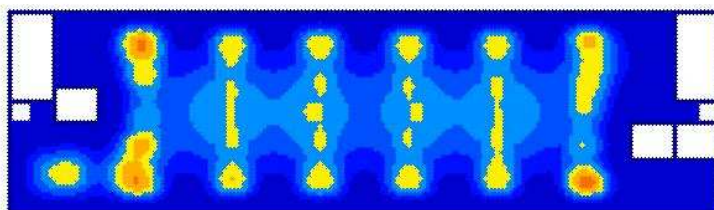

**Figure 3.2: Variation in vibration performance over a typical floor**

### 3.1.5. Detailed procedure

The exact calculation procedure, including input values such as Fourier coefficients for walking and dancing activities and Standard defined acceptability criteria are given in SCI publication 354, entitled "Design of Floors for Vibration: A New Approach"[2]. This also includes guidance on the modelling of floors in finite element software.

The P354 method gives similar results to those using the OS-RMS<sub>90</sub> method, but gives a value that is more directly comparable to the limits given in Standards such as ISO 10137. The effect of vibration travelling across the floor plate, such as from a busy corridor into a sensitive operating theatre, can be taken into account, and different weighting factors can be used for different scenarios. It also allows for different excitations to be considered, be they from walking or dancing activities or from machinery, and for the effect of vibration on different receivers (such as sensitive measuring equipment) to be investigated.

### 3.2. Other vibration considerations

Another important aspect of vibration design considered in P354 is the magnification of loads during rhythmic activities. Human activities that can induce vibration always subject the floor to a load greater than the static load, but in the case of walking this increase is insignificant and certainly falls well within the imposed loads considered for design. However, when a group of people is involved in combined rhythmic activity (usually in response to music, so aerobics or dancing, for example) the additional load caused by the activity can exceed the loads that are considered for design, and must be explicitly taken into account. In extreme cases this can also cause fatigue problems with the structure.

### 3.3. Simplified approach

As an alternative to producing a finite element model of the structure, P354 presents a simplified, hand calculation approach. This is based on a parametric study of a number of models using the modal superposition approach, and again calculates an acceleration that can be compared to limiting values in Standards.

## 4.Improving structures

The three most effective ways of improving the response of a floor can be seen by considering the OS-RMS<sub>90</sub> plots. Two of these plots, at different damping levels, are reproduced in Figure 4.1.

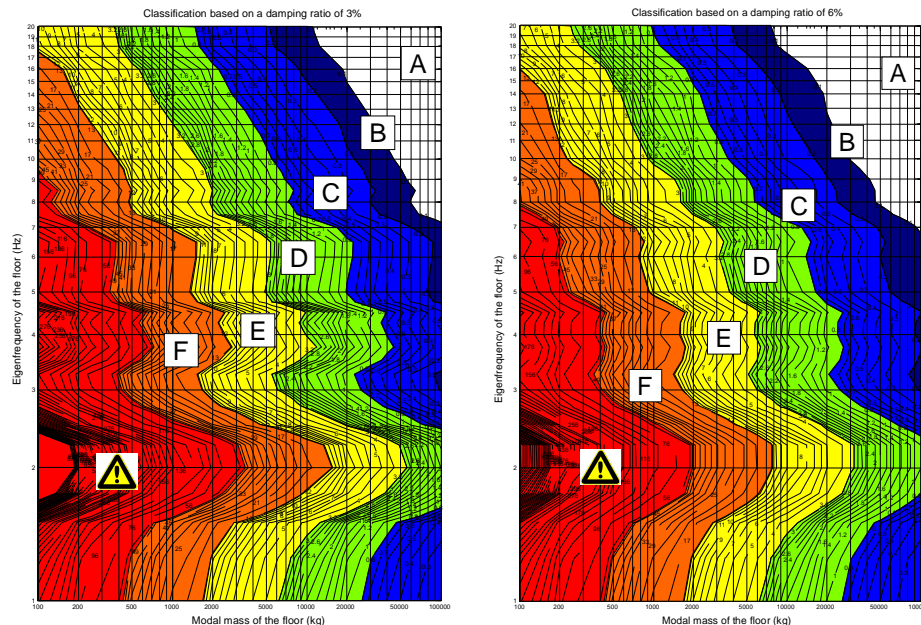

**Figure 4.1 OS-RMS plots for 3% damping (left) and 6% damping (right)**

It is clear from these plots that the vibration performance of the floor can be improved in three different ways: increasing the modal mass (i.e. moving from left to right within a plot); adjusting the frequency (i.e. moving vertically within a plot); or increasing the damping (i.e. moving from the same point on the left plot to the equivalent point on the right plot). When using more advanced methods of analysis, it is also possible to adjust the framing to isolate areas of the floor – useful when considering the vibration of operating theatres in hospitals.

### 4.1. Increasing the modal mass

Usually the most effective way of improving the vibration performance of a structure is to increase the amount of mass participating in the motion. This can be done either by increasing the distributed mass of the floor (by increasing the slab depth, adding a screed, etc.), or by adjusting the stiffnesses of the supporting steelwork to make a larger area of the floor participate in the mode shape. A larger floor area will naturally have a larger modal mass, and this will help to reduce the floor response. However, adding mass to the structure will also affect the frequency, and so care should be taken to ensure that the structure

does not become more responsive even with the additional mass as a result of a lower frequency.

#### 4.2. Adjusting the frequency

The frequency of the floor plate can easily be increased by increasing the beam stiffness or, in existing structures, adding plates to the flanges of the steelwork. The benefits of this are not necessarily significant though, as until the floor frequency is above 9-10 Hz, there is little frequency dependence in the vibration performance, and only "tuning" the structure between the harmonics of the excitation function will improve the response.

#### 4.3. Increasing the damping

In theory the most effective way of reducing the vibration response of a floor is to increase the damping that is present, as the magnitude of the floor response will approximately half if the damping is doubled. However, it is difficult to add damping to floors, as damping systems generally need to be connected to points where there is a lot of motion for them to be fully effective. This would mean attaching dampers between floors in the centre of beams or slabs, and this is impractical in most circumstances. Significant damping can be added by the use of tuned mass dampers, but this is generally not a consideration at the design stage, and is used more as a remedial measure.

#### 4.4. Structural means

For particularly sensitive areas of the floor, such as operating theatres, it may be preferable to isolate the area from the remainder of the floor rather than to try and design the entire floor plate to meet the stringent requirements of the sensitive area. This can be achieved by providing areas with different framing layouts (different spans, for example), by providing beams with significantly higher stiffnesses than the typical beams, or by adding in additional columns around the sensitive areas. The easiest way of assessing these changes is to model the floor in finite element software, and adjust the layout until the mode shapes show the isolation of the sensitive areas.

#### 4.5. Retrofit measures

Remedial action is often expensive and sometimes practicably impossible within realistic physical constraints. In some situations, it may be feasible to use measures which will merely reduce the annoyance associated with the vibration instead of altering the nature or extent of the vibration itself. Such measures include removing or reducing associated annoyance factors such as noise caused by vibrating components, altering the timing of the problem-

causing activity, or changing the architectural layout to move occupants away from problem areas.

In general, the methods of improving structures detailed above apply equally to retrofit measures. Changing the floor mass as a retrofit measure can be effective, but care must be taken that the frequency of the floor doesn't reduce such that the beneficial effect of the additional mass is counteracted. The frequency itself can be raised by welding additional steel to the flanges of the existing beams, and used in combination with an increase in mass (through a screed, for example) the vibration response can be significantly improved.

The damping of the structure can also be improved, and the usual methods of achieving this are:

- ❖ Changing the placement of non-structural components such as partitions
- ❖ Provision of tuned mass dampers
- ❖ Provision of specialist damping materials

Changing the position or increasing the number of non-structural components will aid the damping of a floor system. Unfortunately, as damping is an extremely variable characteristic, it is impossible to accurately quantify the exact improvement which will be provided by increasing such components. Generally performance testing will be required to establish the effectiveness of these remedial measures, and trial and error may have to be used to obtain improvements.

Tuned mass dampers, which exhibit a passive control of floor movement, may be utilised to reduce the response of the floor to forcing actions such as footfall. A tuned mass damper (TMD) is a mass attached to the floor structure through a spring and damping device. A TMD is effective, however, only if the natural frequency of the TMD closely correlates with that of the troublesome mode of floor vibration. TMDs which are initially tuned to the floor vibration modes may become out-of-tune due to changes in the floor's natural frequencies resulting from alterations to the floor characteristics or movement of materials locally. It should be noted that TMDs have a limited frequency range where they are effective. As a consequence of this, a floor with several problematic frequencies may need several TMDs to reduce the floor response. Typically, the mass of a TMD will be between 2% and 5% of the modal mass for each mode that needs tuning, and this can result in problems supporting the additional load.

Specialist materials are generally used in constrained layer damping systems. Materials with high energy dissipation are sandwiched between the existing structure and an additional sheet of metal, and the strains that are subsequently induced in the layer (both direct tension/compression and shear) dissipate energy by hysteresis. Specialist advice should be sought to determine whether this method of damping is appropriate and beneficial (e.g. the effectiveness of the material may be dependent on temperature or the amplitude of the strains).

## 5. References

- [1] European Commission – Technical Steel Research: “Generalisation of criteria for floor vibrations for industrial, office, residential and public building and gymnastic halls”, RFCS Report EUR 21972 EN, ISBN 92-79-01705-5, 2006, <http://europa.eu.int>
- [2] A.L. Smith, S. J. Hicks, P. J. Devine: “Design of Floors for Vibration: A New Approach”. SCI 2007, ISBN 1-85942-176-8
- [3] Waarts, P. *Trillingen van vloeren door lopen: Richtlijn voor het voorspellen, meten en beoordelen*. SBR, September 2005.
- [4] ISO 10137 – Bases for design of structure – Serviceability of buildings and walkways against vibrations, International Organization for Standardization, 2007.