



**Apollo Bridge**  
Architect: Ing. Miroslav Maťaščík - Alfa 04 a.s., Bratislava  
Design: DOPRAVOPROJEKT a.s., Bratislava

# Ontwerp van koudgevormde stalen gordingen volgens EN 1993-1-3 met Scia Engineer 2010

## Opzet

Berekening in **Uiterste Grenstoestand** van een **koudgeformde** gording , gesteund door een **beplating** aan de bovenzijde en belast door een **opwaartse** belasting.

## Normen

- EN 1993-1-3:2006/AC:2009
- EN 1993-1-5:2006/AC:2009
- EN 1993-1-1:2005/AC:2009

## Nationale Bijlage

- Berekening volgens standaard EN
- Vermelding van de Nationaal Bepaalde Parameters

Overzicht van de theorie, geïllustreerd met een voorbeeld in **Scia Engineer 2010**



## Inhoud

### **Rekenmodel en Uitgangspunten**

- Uitgangspunt
- Doorsnede
- Belasting
- Mag EN 1993-1-3 worden toegepast?

### **Berekening van de Effectieve Doorsnede**

- Inleiding
- Bepaling van de notionele breedte
- Lokaal plooien van de elementen onder druk
- Distortieknik van de verstijvers met optionele iteraties
- Optioneel: Iteratieve berekening van de volledige doorsnede

### **Standaard UGT Controles (Niet specifiek voor gordingen)**

- Controle op Buiging
- Controle op Dwarskracht
- Controle op Lokale Dwarse Krachten
- Interactie Moment en Lokale Dwarse Kracht

### **Speciale UGT Controles (Specifiek voor gordingen)**

- Ligger gesteund door beplating
- Ligger op verende bedding
- Weerstand van de doorsnede
- Knikweerstand van de vrije flens

## Rekenmodel en Uitgangspunten

# Rekenmodel

## Uitgangspunt

3D Stalen hal

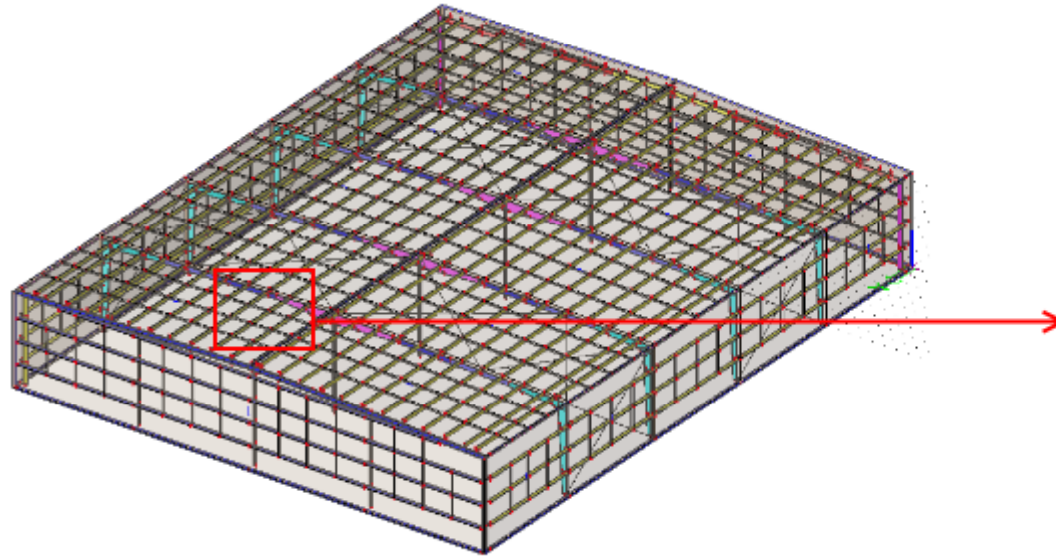

Detail van de dakopbouw

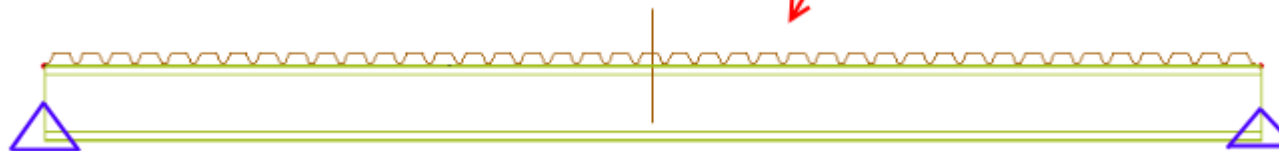
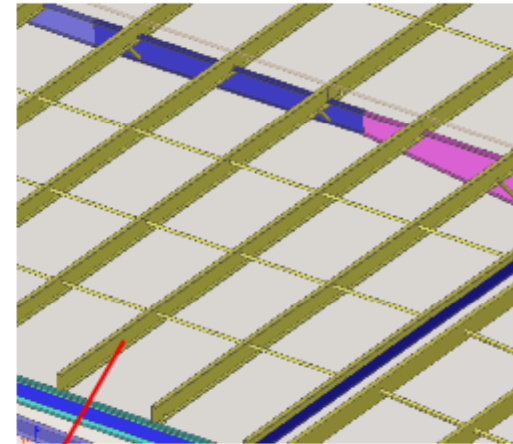

Gording op 2 steunpunten, gesteund door beplating aan de bovenzijde

# Rekenmodel

## Doorsnede

Sadef C 200 x 3.00 S390GD + Z

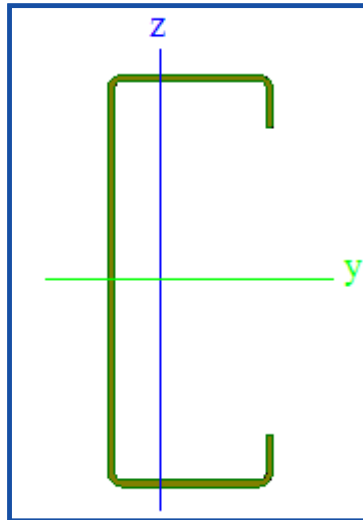

Nominale dikte **3 mm**

Kerndikte volgens **EN 1993-1-3 art. 3.2.4** ten gevolge van zink coating

Staal kerndikte	
Inschakelen	<input checked="" type="checkbox"/>
Metalen deklaag [mm]	0,04

⇒ Kerndikte = **2,96 mm**

Deze dikte moet gebruikt worden in het ontwerp !

Herberekende eigenschappen  
van de bruto doorsnede

Eigenschap	
A [mm <sup>2</sup> ]	1,1451e+03
A <sub>y</sub> [mm <sup>2</sup> ]	2,9643e+02
A <sub>z</sub> [mm <sup>2</sup> ]	4,5674e+02
AL [m <sup>2</sup> /m]	7,8310e-01
I <sub>t</sub> [mm <sup>4</sup> ]	3,3171e+03
I <sub>y</sub> [mm <sup>4</sup> ]	7,0407e+06
I <sub>z</sub> [mm <sup>4</sup> ]	9,9160e+05
I <sub>w</sub> [mm <sup>6</sup> ]	8,2257e+09
alpha [deg]	0,00
W <sub>e<sub>y</sub></sub> [mm <sup>3</sup> ]	7,1479e+04
W <sub>e<sub>z</sub></sub> [mm <sup>3</sup> ]	1,8560e+04
W <sub>p<sub>y</sub></sub> [mm <sup>3</sup> ]	8,5743e+04
W <sub>p<sub>z</sub></sub> [mm <sup>3</sup> ]	2,7083e+04
c <sub>Y</sub> LCS [mm]	-14,89
c <sub>Z</sub> LCS [mm]	0,00
d <sub>y</sub> [mm]	-61,01
d <sub>z</sub> [mm]	0,00

# Rekenmodel

## Belasting

Beschouwde belasting: **Opwaarts**

**LC1:** Permanente puntlast **2 kN** in het midden

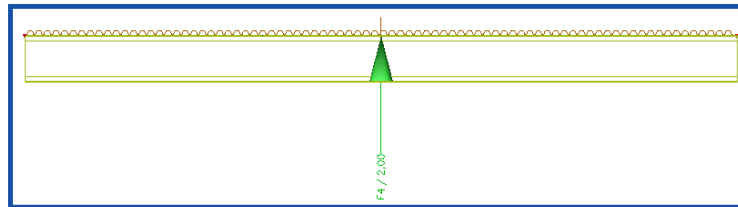

**LC2:** Variabele lijnlast **2 kN/m**

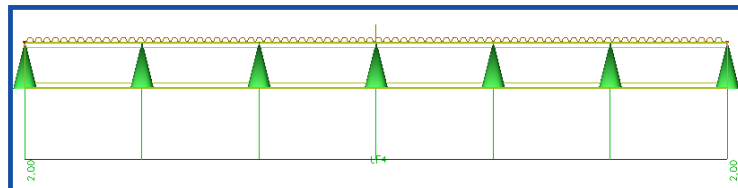

Systeemplengte **3m**

Gegeneerde combinaties **UGT (STR / GEO) – Set B (vgl 6.10)**

Naam	Omschrijving van de combinaties
1	LC1*1.35 +LC2*1.50
2	LC1*1.35
3	LC1*1.00

Interne krachten **Vz** en **My**

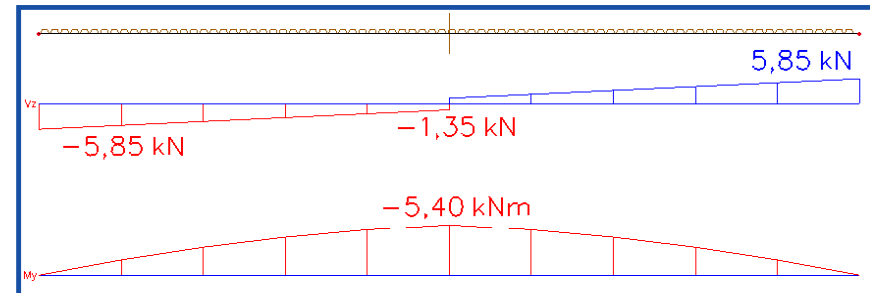

⇒Effectieve doorsnede voor negatief moment **My**

# Rekenmodel

## Mag EN 1993-1-3 worden toegepast?

Mag EN 1993-1-3 worden toegepast zonder bijkomende testen?

### a) Voorwaarde voor kerndikte: EN 1993-1-3 art. 3.2.4(1)

(1) The provisions for design by calculation given in this Part 1-3 of EN 1993 may be used for steel within given ranges of core thickness  $t_{cor}$ .

**NOTE:** The ranges of core thickness  $t_{cor}$  for sheeting and members may be given in the National Annex. The following values are recommended:

- for sheeting and members:  $0,45 \text{ mm} \leq t_{cor} \leq 15 \text{ mm}$

- for connections:  $0,45 \text{ mm} \leq t_{cor} \leq 4 \text{ mm}$ , see 8.1(2)



**Opgelet:** de voorwaarde voor de kerndikte betreft een Nationaal Bepaalde Parameter !

Standaard EN:

<b>Minimaal</b>	
Waarde [mm]	0,45
<b>Maximaal</b>	
Waarde [mm]	15,00

Nederlandse Nationale Bijlage:

<b>Minimaal</b>	
Waarde [mm]	1,00
<b>Maximaal</b>	
Waarde [mm]	8,00

Belgische Nationale Bijlage:

<b>Minimaal</b>	
Waarde [mm]	0,45
<b>Maximaal</b>	
Waarde [mm]	15,00

Duitse Nationale Bijlage:

<b>Minimaal</b>	
Waarde [mm]	0,45
<b>Maximaal</b>	
Waarde [mm]	3,00

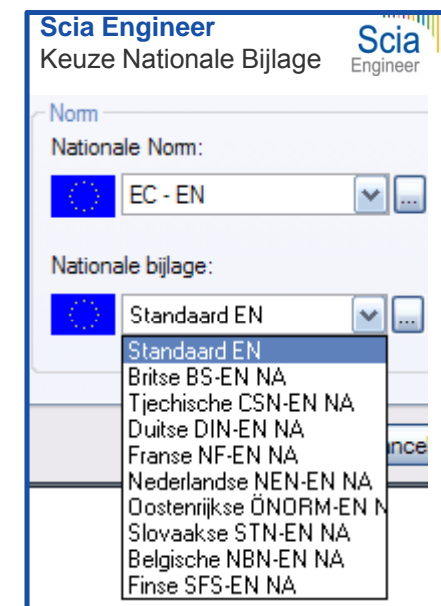

# Rekenmodel

## Mag EN 1993-1-3 worden toegepast?

Mag EN 1993-1-3 worden toegepast zonder bijkomende testen?

b) Voorwaarden voor doorsnede geometrie: EN 1993-1-3 art. 5.2(1)

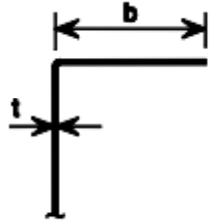
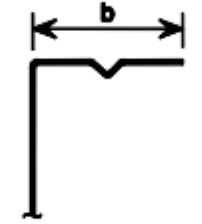
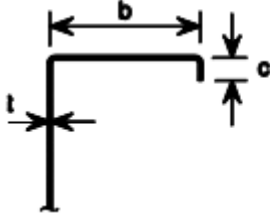
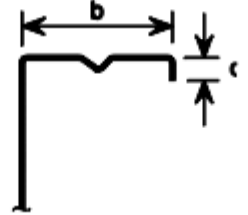

		$b/t \leq 50$
		$b/t \leq 60$ $c/t \leq 50$

c) Voorwaarde voor verstijvers: EN 1993-1-3 art. 5.2(2)

(2) In order to provide sufficient stiffness and to avoid primary buckling of the stiffener itself, the sizes of stiffeners should be within the following ranges:

$$0,2 \leq c/b \leq 0,6$$

... (5.2a)

$$0,1 \leq d/b \leq 0,3$$

... (5.2b)

Sadef C 200 x 3.00 voldoet aan de gestelde eisen

## Berekening van de Effectieve Doorsnede

# Effectieve Doorsnede

## Inleiding

De berekening van de effectieve doorsnede kan worden ingedeeld in volgende stappen:



- A) Bepaling van de notionele breedte van de elementen
- B) Lokaal plooien van de elementen onder druk
- C) Distortieknik van de verstijvers met optionele iteraties
- D) Optioneel: Iteratieve berekening van de volledige doorsnede

# Effectieve Doorsnede

## A) Bepaling van de notionele breedte

Invloed van afgeronde hoeken volgens EN 1993-1-3 art. 5.1

Theorie

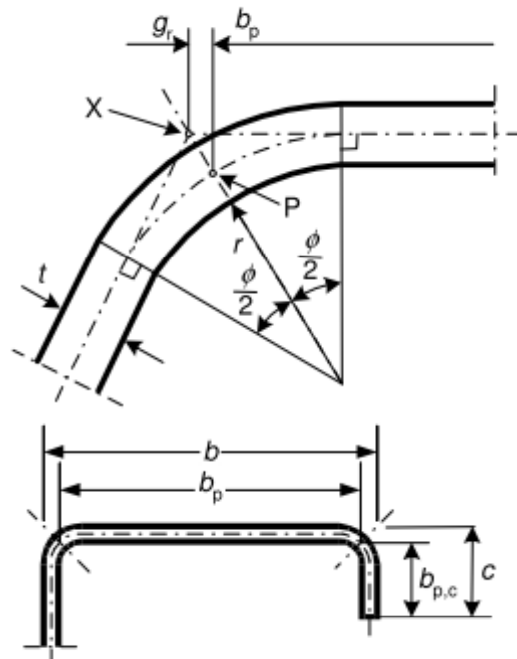

(a) midpoint of corner or bend

X is intersection of midlines

P is midpoint of corner

$$r_m = r + t / 2$$

$$g_r = r_m \left( \tan\left(\frac{\phi}{2}\right) - \sin\left(\frac{\phi}{2}\right) \right)$$

# Effectieve Doorsnede

## A) Bepaling van de notionele breedte

Invloed van afgeronde hoeken volgens EN 1993-1-3 art. 5.1

Scia Engineer

Opdeling van de doorsnede in onderdelen en berekening van de notionele breedte

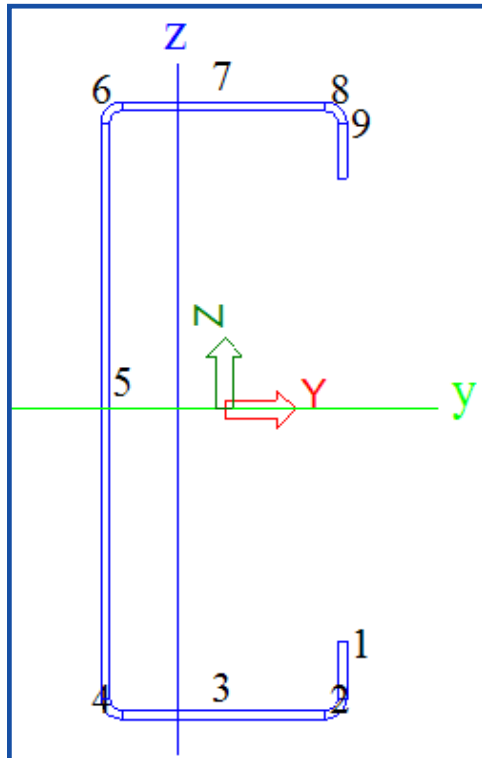

Element	bp[mm]
1	21.91
3	73.83
5	193.83
7	73.83
9	21.91



# Effectieve Doorsnede

## B) Lokaal plooien van de elementen onder druk



Lokaal plooien volgens EN 1993-1-5 art. 4.4

Scia Engineer



Berekening van de effectieve breedte

**Effectieve doorsnede My -**  
**Effectieve breedte berekening**  
Volgens EN 1993-1-3 artikel 5.5.2, 5.5.3 & EN 1993-1-5 artikel 4.4

Element	bp[mm]	f1[N/mm <sup>2</sup> ]	f2[N/mm <sup>2</sup> ]	Psi[-]	k,sigma[-]	Lambda,p[-]	Rho[-]	beff[mm]	be1[mm]	be2[mm]
1	21.91	383.646	296.894	0.774	0.500	0.475	1.000	21.91		
3	73.83	390.000	390.000	1.000	4.000	0.566	1.000	73.83	36.91	36.91
5	193.83	383.868	-367.325	-0.957	22.784	0.622	1.000	99.05	39.62	59.43
7	73.83	-373.633	-377.684							
9	21.91	-296.894	-383.646							

# Effectieve Doorsnede

## C) Distortieknik van de verstijvers met optionele iteraties

Distortieknik volgens EN 1993-1-3 art. 5.5.3

Theorie



De werkelijke geometrie wordt vervangen door een equivalent systeem met translatievoor  $K$

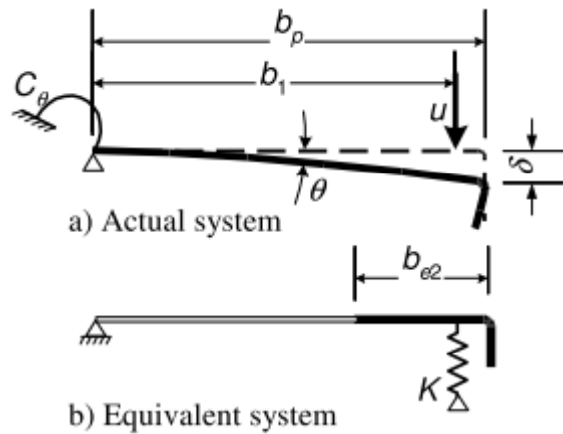

$$K_1 = \frac{Et^3}{4(1-\nu^2)} \cdot \frac{1}{b_1^2 h_w + b_1^3 + 0,5b_1 b_2 h_w k_f}$$

# Effectieve Doorsnede

## C) Distortieknik van de verstijvers met optionele iteraties

Distortieknik volgens EN 1993-1-3 art. 5.5.3

### Theorie

De effectieve geometrie van de verstijver en de translatieveer  $K$  worden gebruikt voor de berekening van de kritieke knikspanning  $\sigma_{cr,s}$  van de verstijver.

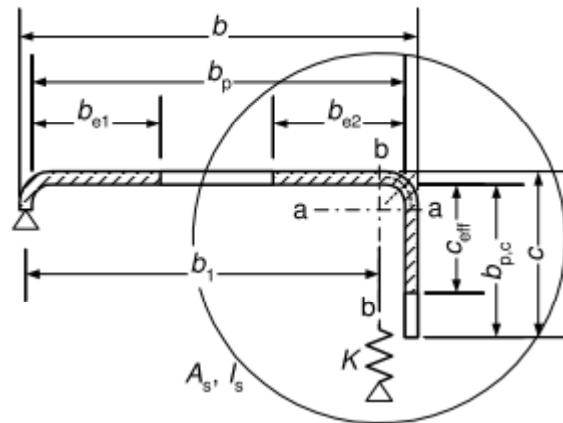

$$\sigma_{cr,s} = \frac{2 \sqrt{K E I_s}}{A_s}$$

Standaardformule voor de kritieke knikspanning van een “ligger op verende bedding”

# Effectieve Doorsnede

## C) Distortieknik van de verstijvers met optionele iteraties

Distortieknik volgens EN 1993-1-3 art. 5.5.3

### Theorie

De kritieke knikspanning  $\sigma_{cr,s}$  van de verstijver wordt gebruikt voor de berekening van de relatieve slankheid en de reductiefactor voor knik  $\chi_d$ .



$$\bar{\lambda}_d = \sqrt{f_{yb} / \sigma_{cr,s}}$$

$$\chi_d = 1,0 \quad \text{if } \bar{\lambda}_d \leq 0,65$$

$$\chi_d = 1,47 - 0,723\bar{\lambda}_d \quad \text{if } 0,65 < \bar{\lambda}_d < 1,38$$

$$\chi_d = \frac{0,66}{\bar{\lambda}_d} \quad \text{if } \bar{\lambda}_d \geq 1,38$$

# Effectieve Doorsnede

## C) Distortieknik van de verstijvers met optionele iteraties

Distortieknik volgens EN 1993-1-3 art. 5.5.3

Theorie – Algemene procedure

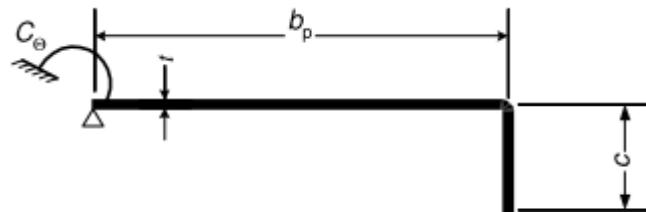

a) Gross cross-section and boundary conditions

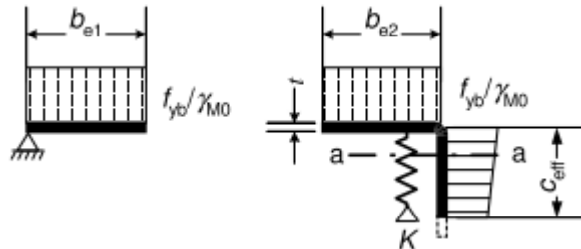

b) **Step 1:** Effective cross-section for  $K = \infty$  based on  $\sigma_{com,Ed} = f_{yb} / \gamma_{M0}$

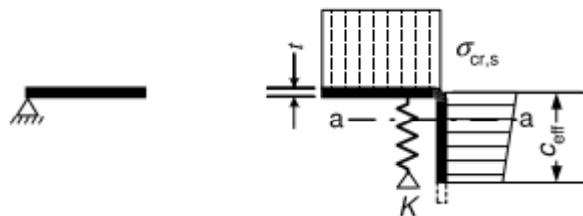

c) **Step 2:** Elastic critical stress  $\sigma_{cr,s}$  for effective area of stiffener  $A_s$  from step 1

# Effectieve Doorsnede

## C) Distortieknik van de verstijvers met optionele iteraties

Distortieknik volgens EN 1993-1-3 art. 5.5.3

Theorie – Algemene procedure

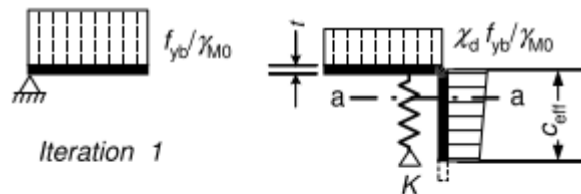

d) Reduced strength  $\chi_d f_{yb}/\chi_{M0}$  for effective area of stiffener  $A_s$ , with reduction factor  $\chi_d$  based on  $\sigma_{cr,s}$

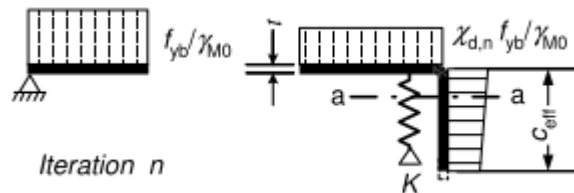

e) **Step 3:** Optionally repeat step 1 by calculating the effective width with a reduced compressive stress  $\sigma_{com,Ed,i} = \chi_d f_{yb} / \chi_{M0}$  with  $\chi_d$  from previous iteration, continuing until  $\chi_{d,n} \approx \chi_{d,(n-1)}$  but  $\chi_{d,n} \leq \chi_{d,(n-1)}$ .

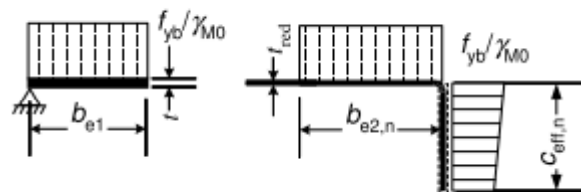

f) Adopt an effective cross-section with  $b_{e2}$ ,  $c_{eff}$  and reduced thickness  $t_{red}$  corresponding to  $\chi_{d,n}$

# Effectieve Doorsnede

## C) Distortieknik van de verstijvers met optionele iteraties

Distortieknik volgens EN 1993-1-3 art. 5.5.3

Theorie – Algemene procedure – Opmerking



**Opgelet:** de veiligheidsfactoren betreffen Nationaal Bepaalde Parameters !

Standaard EN:

<b>Gamma M0</b>	
Waarde [-]	1,00
<b>Gamma M1</b>	
Waarde [-]	1,00
<b>Gamma M2</b>	
Waarde [-]	1,25

Nederlandse Nationale Bijlage:

<b>Gamma M0</b>	
Waarde [-]	1,00
<b>Gamma M1</b>	
Waarde [-]	1,00
<b>Gamma M2</b>	
Waarde [-]	1,25

Belgische Nationale Bijlage:

<b>Gamma M0</b>	
Waarde [-]	1,00
<b>Gamma M1</b>	
Waarde [-]	1,00
<b>Gamma M2</b>	
Waarde [-]	1,25

Duitse Nationale Bijlage:

<b>Gamma M0</b>	
Waarde [-]	1,10
<b>Gamma M1</b>	
Waarde [-]	1,10
<b>Gamma M2</b>	
Waarde [-]	1,25

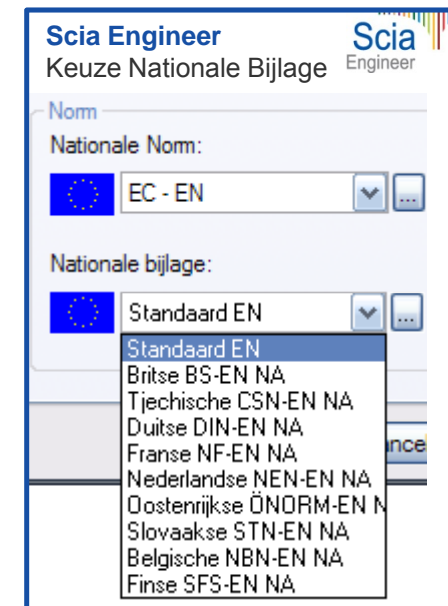

# Effectieve Doorsnede

## C) Distortieknik van de verstijvers met optionele iteraties

Distortieknik volgens EN 1993-1-3 art. 5.5.3

Scia Engineer

Optionele iteraties van de verstijvers

<input checked="" type="checkbox"/> Lokale en Distortieknik	EN 1993-1-3: 5.5.2 & 5...
Verstijver iteratie 5.5.3.2(10) en 5.5.3.3(9)	<input checked="" type="checkbox"/> ja

Distortieknik van de verstijvers met invloed op het lokaal plooiën

**Effectieve doorsnede My-  
Effectieve breedte berekening**  
Volgens EN 1993-1-3 artikel 5.5.2, 5.5.3 & EN 1993-1-5 artikel 4.4

Element	bp[mm]	f1[N/mm²]	f2[N/mm²]	Psi[-]	k,sigma[-]	Lambda,p[-]	Lambda,p,red[-]	Rho[-]	beff[mm]	be1[mm]	be2[mm]
1	21.91	379.841	294.709	0.778	0.500	0.475	0.445	1.000	21.91		
3	73.83	390.000	385.950	0.990	4.020	0.564	0.528	1.000	73.83	38.82	37.01
5	193.83	383.888	-387.279	-0.957	22.781	0.622		1.000	99.08	39.62	59.43
7	73.83	-373.588	-377.646								
9	21.91	-288.619	-371.551								

**Verstijver berekening**  
Volgens EN 1993-1-3 artikel 5.5.3

Element	As[mm²]	Is[mm⁴]	b1[mm]	b2[mm]	hw[mm]	kf[-]	K[N/mm²]	Sigma,cr[N/mm²]	Lambda,d[-]	Chi,d[-]	As,red[mm²]
1	1.7893e+02	9.0975e+03	84.54	49.41	197.04	0.000	1.373	578.961	0.821	0.877	1.5509e+02

# Effectieve Doorsnede

## D) Optioneel: Iteratieve berekening van de volledige doorsnede

Iteraties over de volledige doorsnede volgens EN 1993-1-3 art. 5.5.2

### Theorie



- (3) In applying the method in EN 1993-1-5 the following procedure may be used:
- The stress ratio  $\psi$ , from tables 4.1 and 4.2 used to determine the effective width of flanges of a section subject to stress gradient, may be based on gross section properties.
  - The stress ratio  $\psi$ , from table 4.1 and 4.2 used to determine the effective width of web, may be obtained using the effective area of compression flange and the gross area of the web.
  - The effective section properties may be refined by using the stress ratio  $\psi$  based on the effective cross-section already found in place of the gross cross-section. The minimum steps in the iteration dealing with the stress gradient are two.

# Effectieve Doorsnede



## D) Optioneel: Iteratieve berekening van de volledige doorsnede

Iteraties over de volledige doorsnede volgens EN 1993-1-3 art. 5.5.2

Scia Engineer



Optionele iteraties over de volledige doorsnede

<b>Lokale en Distortieknik</b>	EN 1993-1-3: 5.5.2 & 5....
Verstijver iteratie 5.5.3.2(10) en 5.5.3.3(9)	<input checked="" type="checkbox"/> ja
Algemene doorsnede iteratie 5.5.2(3)	<input checked="" type="checkbox"/> ja

Finale effectieve doorsnede

Element	bp[mm]	f1[N/mm <sup>2</sup> ]	f2[N/mm <sup>2</sup> ]	Psi[-]	k,sigma[-]	Lambda,p[-]	Lambda,p,red[-]	Rho[-]	beff[mm]	be1[mm]	be2[mm]
1	21.91	379.841	294.709	0.776	0.500	0.475	0.445	1.000	21.91		
3	73.83	390.000	385.950	0.990	4.020	0.584	0.528	1.000	73.83	36.82	37.01
5	193.83	383.868	-367.279	-0.957	22.781	0.622		1.000	99.08	39.62	59.43
7	73.83	-373.588	-377.646								
9	21.91	-286.619	-371.551								

Element	As[mm <sup>2</sup> ]	Is[mm <sup>4</sup> ]	b1[mm]	b2[mm]	hw[mm]	kf[-]	K[N/mm <sup>2</sup> ]	Sigma,of[N/mm <sup>2</sup> ]	Lambda,d[-]	Chi,d[-]	As,red[mm <sup>2</sup> ]
1	1.7693e+02	9.0975e+03	84.54	49.41	197.04	0.000	1.373	578.961	0.821	0.877	1.5509e+02

Effectieve doorsnede eigenschappen

A	Iy	Iz	IYLC S	IZLC S	IYZLC S	Wely	Welz	Wply	Wplz	dy	dz	cYLC S	cZLC S	alpha
[mm <sup>2</sup> ]	[mm <sup>4</sup> ]	[mm <sup>4</sup> ]	[mm <sup>4</sup> ]	[mm <sup>4</sup> ]	[mm <sup>4</sup> ]	[mm <sup>3</sup> ]	[mm <sup>3</sup> ]	[mm <sup>3</sup> ]	[mm <sup>3</sup> ]	[mm]	[mm]	[mm]	[mm]	[deg]
1.1287e+03	6.8977e+06	9.5904e+05	6.8965e+06	9.6024e+05	-8.4217e+04	6.7590e+04	1.6827e+04	8.0893e+04	2.5969e+04	-58.23	-2.03	-15.66	-1.82	0.81

# Effectieve Doorsnede

## D) Optioneel: Iteratieve berekening van de volledige doorsnede

Iteraties over de volledige doorsnede volgens EN 1993-1-3 art. 5.5.2

Scia Engineer

Finale effectieve doorsnede

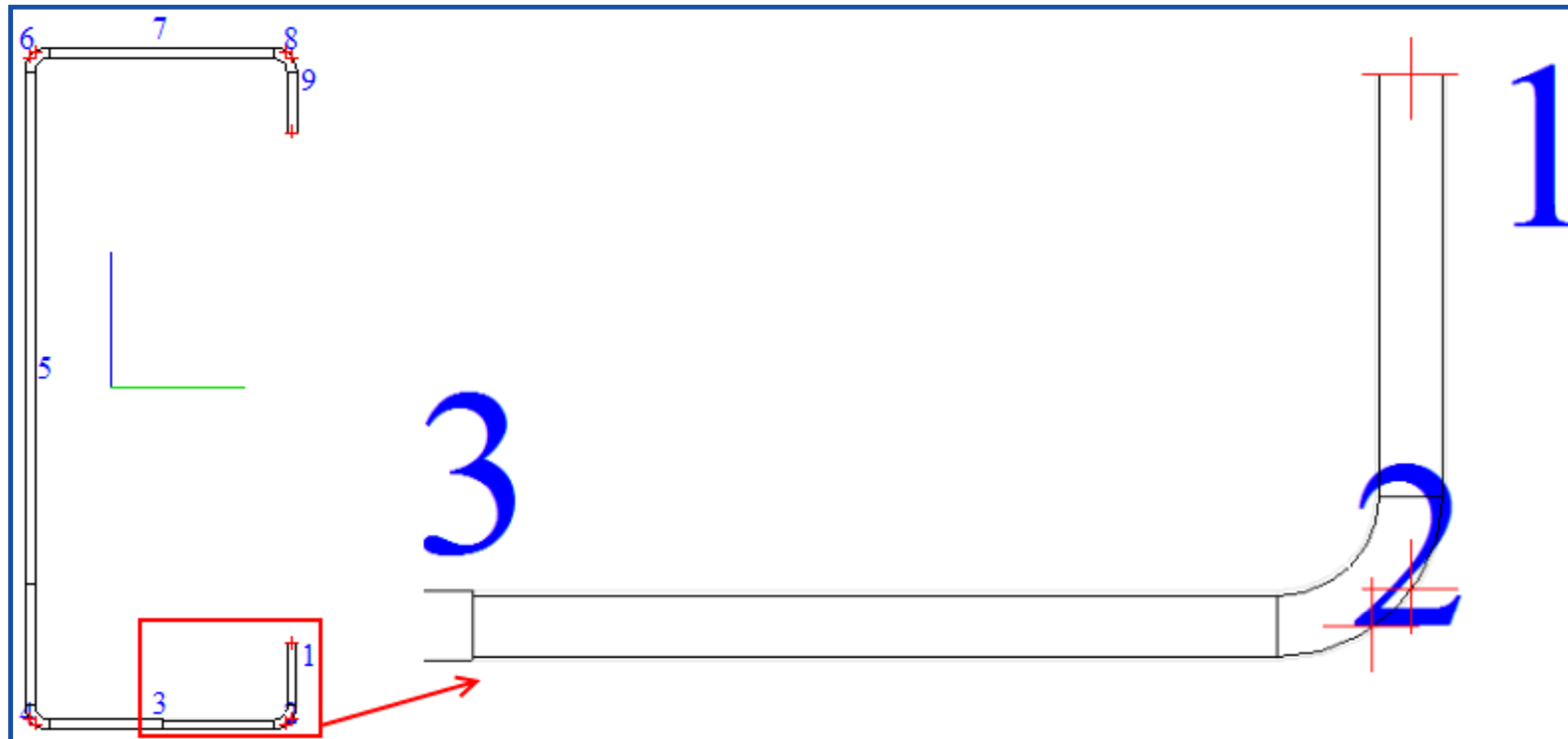

# Standaard Controles



Standaard UGT Controles (Niet specifiek voor gordingen)

# Standaard Controles

## Controle op Buiging

### Buigingscontrole volgens EN 1993-1-3 art. 6.1.4

#### Theorie



(1) The design moment resistance of a cross-section for bending about one principal axis  $M_{c,Rd}$  is determined as follows (see figure 6.2):

- if the effective section modulus  $W_{eff}$  is less than the gross elastic section modulus  $W_{el}$

$$M_{c,Rd} = W_{eff} f_{yb} / \gamma_{M0} \quad \dots(6.4)$$

- if the effective section modulus  $W_{eff}$  is equal to the gross elastic section modulus  $W_{el}$

$$M_{c,Rd} = f_{yb} (W_{el} + (W_{pl} - W_{el})4(1 - \bar{\lambda}_{e,max} / \bar{\lambda}_{e0})) / \gamma_{M0} \text{ but not more than } W_{pl} f_{yb} / \gamma_{M0} \quad \dots(6.5)$$

where

$\bar{\lambda}_{e,max}$  is the slenderness of the element which correspond to the largest value of  $\bar{\lambda}_e / \bar{\lambda}_{e0}$  ;

For double supported plane elements  $\bar{\lambda}_e = \bar{\lambda}_p$  and  $\bar{\lambda}_{e0} = 0,5 + \sqrt{0,25 - 0,055(3 + \psi)}$  where  $\psi$  is the stress ratio, see 5.5.2;

For outstand elements  $\bar{\lambda}_e = \bar{\lambda}_p$  and  $\bar{\lambda}_{e0} = 0,673$ , see 5.5.2;

# Standaard Controles

## Controle op Buiging



Buigingscontrole volgens EN 1993-1-3 art. 6.1.4

Scia Engineer



Controle in de snede in het midden van de gording

**Buigend Moment Controle**  
**Buigend Moment My**  
Volgens artikel EN 1993-1-3: 6.1.4.1 en formule (6.4)

Buiging rond de Y as		
Wel,y	70938.23	mm <sup>3</sup>
Weff,y	67589.78	mm <sup>3</sup>
Mcy,Rd	26.36	kNm
Eenheidscontrole	0.20	-

# Standaard Controles

## Controle op Dwarskracht

### Dwarskrachtcontrole volgens EN 1993-1-3 art. 6.1.5

#### Theorie

(1) The design shear resistance  $V_{b,Rd}$  should be determined from:

$$V_{b,Rd} = \frac{h_w}{\sin \phi} \frac{t f_{bv}}{\gamma_{M0}} \quad \dots (6.8)$$

where:

- $f_{bv}$  is the shear strength considering buckling according to Table 6.1;
- $h_w$  is the web height between the midlines of the flanges, see figure 5.1(c);
- $\phi$  is the slope of the web relative to the flanges, see figure 6.5.



**Table 6.1: Shear buckling strength  $f_{bv}$**

Relative web slenderness	Web without stiffening at the support	Web with stiffening at the support <sup>1)</sup>
$\bar{\lambda}_w \leq 0,83$	$0,58 f_{yb}$	$0,58 f_{yb}$
$0,83 < \bar{\lambda}_w < 1,40$	$0,48 f_{yb} / \bar{\lambda}_w$	$0,48 f_{yb} / \bar{\lambda}_w$
$\bar{\lambda}_w \geq 1,40$	$0,67 f_{yb} / \bar{\lambda}_w^2$	$0,48 f_{yb} / \bar{\lambda}_w$

<sup>1)</sup> Stiffening at the support, such as cleats, arranged to prevent distortion of the web and designed to resist the support reaction.

for webs without longitudinal stiffeners

$$\bar{\lambda}_w = 0,346 \frac{s_w}{t} \sqrt{\frac{f_{yb}}{E}}$$

# Standaard Controles

## Controle op Dwarskracht

### Dwarskrachtcontrole volgens EN 1993-1-3 art. 6.1.5

#### Scia Engineer

Controle in de snede in het midden van de gording

Dwarskracht Vz						
Volgens artikel EN 1993-1-3: 6.1.5 en formule (6.8).						
Geen verstijving aan het steunpunt.						
Element ID	lc [mm]	Alpha [deg]	sw [mm]	Lambda,w [-]	fbv [MPa]	Vb,Rd,z,i [kN]
3	77.04	0.00	73.83	0.37	226.2	0.00
5	197.04	90.00	193.83	0.98	191.7	111.82
7	77.04	0.00	73.83	0.37	226.2	0.00

Tabel van waarden		
Vb,Rd,z	111.82	kN
Eenheidscontrole	0.01	-

⇒ Controle < 0,50 dus geen interactie van dwarskracht en moment vereist

Controle in de snede aan het uiteinde van de gording

Dwarskracht Vz						
Volgens artikel EN 1993-1-3: 6.1.5 en formule (6.8).						
Geen verstijving aan het steunpunt.						
Element ID	lc [mm]	Alpha [deg]	sw [mm]	Lambda,w [-]	fbv [MPa]	Vb,Rd,z,i [kN]
3	77.04	0.00	73.83	0.37	226.2	0.00
5	197.04	90.00	193.83	0.98	191.7	111.82
7	77.04	0.00	73.83	0.37	226.2	0.00

Tabel van waarden		
Vb,Rd,z	111.82	kN
Eenheidscontrole	0.05	-

# Standaard Controles

## Controle op Lokale Dwarse Krachten

Controle op lokale dwarse krachten volgens EN 1993-1-3 art. 6.1.7

### Theorie

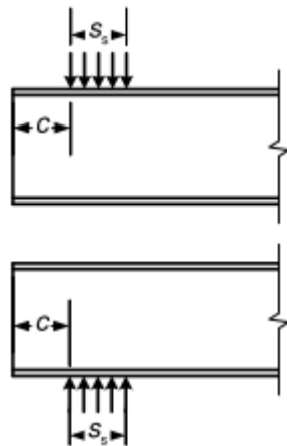

i)  $c \leq 1,5 h_w$  clear from a free end:

- for a cross-section with stiffened flanges:

$$R_{w,Rd} = \frac{k_1 k_2 k_3 \left[ 9,04 - \frac{h_w/t}{60} \right] \left[ 1 + 0,01 \frac{s_s}{t} \right] t^2 f_{yb}}{\gamma_{M1}} \quad (6.15a)$$

$$k_1 = 1,33 - 0,33 k$$

$$k_2 = 1,15 - 0,15 r/t \quad \text{but } k_2 \geq 0,50 \text{ and } k_2 \leq 1,0$$

$$k_3 = 0,7 + 0,3 (\phi/90)^2$$

$$k_4 = 1,22 - 0,22 k$$

$$k_5 = 1,06 - 0,06 r/t \quad \text{but } k_5 \leq 1,0$$

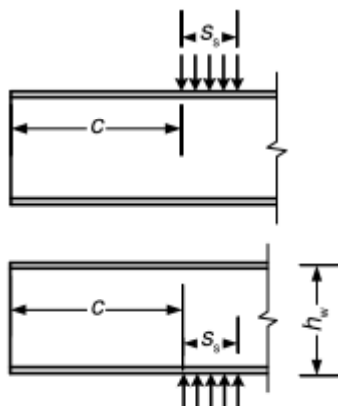

ii)  $c > 1,5 h_w$  clear from a free end:

- if  $s_s/t \leq 60$ :

$$R_{w,Rd} = \frac{k_3 k_4 k_5 \left[ 14,7 - \frac{h_w/t}{49,5} \right] \left[ 1 + 0,007 \frac{s_s}{t} \right] t^2 f_{yb}}{\gamma_{M1}} \quad (6.15d)$$

# Standaard Controles

## Controle op Lokale Dwarse Krachten



Controle op lokale dwarse krachten volgens EN 1993-1-3 art. 6.1.7

Scia Engineer

Controle in de snede in het midden van de gording



### Lokale Dwarse Krachten Controle

Volgens artikel EN 1993-1-3: 6.1.7.2 en formule (6.15d)

Tabel van waarden		
Flens conditie	Verstijfd	
Belastingsconditie	Intern één-flens (IOF)	
Lijf rotatie	Niet verhinderd	
Binnenstraal r	4.00	mm
Oplegqlenqte Ss	100.00	mm
k	1.71	
k1	0.77	
k4	0.84	

Element	lc[mm]	Phi [deg]	hw [mm]	t [mm]	k2	k3	k5	Rw,Rd,i [kN]
5	197.04	90.00	197.04	2.96	0.95	1.00	0.98	46.60

Tabel van waarden		
Last/Reactie FEd	-2.70	kN
Rw,Rd	46.60	kN
Eenheidscontrole	0.06	-

# Standaard Controles

## Controle op Lokale Dwarse Krachten

Controle op lokale dwarse krachten volgens EN 1993-1-3 art. 6.1.7

Scia Engineer

Controle in de snede aan het uiteinde van de gording

### Lokale Dwarse Krachten Controle

Volgens artikel EN 1993-1-3:6.1.7.2 en formule (6.15a)

Tabel van waarden		
Flensconditie	Verstijfd	
Belastingsconditie	Eind één-flens (EOF)	
Lijf rotatie	Niet verhinderd	
Binnenstraal r	4.00	mm
Opleglenkte Ss	100.00	mm
k	1.71	
k1	0.77	
k4	0.84	

Element	lc[mm]	Phi [deg]	hw [mm]	t [mm]	k2	k3	k5	Rw,Rd,i [kN]
5	197.04	90.00	197.04	2.96	0.95	1.00	0.98	26.29

Tabel van waarden		
Last/Reactie FEd	5.85	kN
Rw,Rd	26.29	kN
Eenheidscontrole	0.22	-

# Standaard Controles

## Interactie Moment en Lokale Dwarse Kracht

Interactiecontrole op moment en lokale dwarse kracht volgens EN 1993-1-3 art. 6.1.11

### Theorie



(1) Cross-sections subject to the combined action of a bending moment  $M_{Ed}$  and a transverse force due to a local load or support reaction  $F_{Ed}$  should satisfy the following:

$$M_{Ed} / M_{c,Rd} \leq 1 \quad \dots (6.28a)$$

$$F_{Ed} / R_{w,Rd} \leq 1 \quad \dots (6.28b)$$

$$\frac{M_{Ed}}{M_{c,Rd}} + \frac{F_{Ed}}{R_{w,Rd}} \leq 1,25 \quad \dots (6.28c)$$

where:

$M_{c,Rd}$  is the moment resistance of the cross-section given in 6.1.4.1(1);

$R_{w,Rd}$  is the appropriate value of the local transverse resistance of the web from 6.1.7.

# Standaard Controles

## Interactie Moment en Lokale Dwarse Kracht



Interactiecontrole op moment en lokale dwarse kracht volgens EN 1993-1-3 art. 6.1.11

Scia Engineer

Controle in de snede in het midden van de gording



### Gecombineerde Buigend Moment en Lokale Last/Reactie Controle

Volgens artikel EN 1993-1-3: 6.1.11 en fomule (6.28c).

Tabel van waarden		
FEd	-2.70	kN
Mc,Rd	26.36	kNm
Rw,Rd	46.60	kN
Eenheidscontrole	0.21	-

## Speciale UGT Controles (Specifiek voor gordingen)

# Speciale Controles

## Ligger gesteund door beplating

Mag EN 1993-1-3 Hoofdstuk 10 worden toegepast?

Theorie



a) Voorwaarde voor de doorsnede dimensies: EN 1993-1-3 art. 10.1.1(1)

(1) The provisions given in this clause 10.1 may be applied to beams (called purlins in this Section) of Z, C, Σ, U and Hat cross-section with  $h/t < 233$ ,  $c/t \leq 20$  for single fold and  $d/t \leq 20$  for double edge fold.

⇒ **Sadef C 200 x 3.00** voldoet aan deze eis

b) Voorwaarde voor de translatiestijfheid van de beplating: EN 1993-1-3 art. 10.1.1(6)

$$S \geq \left( EI_w \frac{\pi^2}{L^2} + GI_t + EI_z \frac{\pi^2}{L^2} 0,25 h^2 \right) \frac{70}{h^2}$$

De translatiestijfheid van de beplating kan bepaald worden via volgende benaderende formule:

$$S = 1000 \sqrt{t^3} (50 + 10 \sqrt[3]{b_{\text{roof}}}) \frac{s}{h_w} \quad (N)$$

Voor een meer nauwkeurige berekening kunnen testgegevens van de fabrikant gebruikt worden.

# Speciale Controles

## Ligger gesteund door beplating



Mag EN 1993-1-3 Hoofdstuk 10 worden toegepast?

Scia Engineer

Beplating type **E96/1.50 Hoesch**

Berekening van de translatiestijfheid volgens testgegevens van de fabrikant:



Naam	E96/1.50
I - moment [mm <sup>4</sup> /m]	2930000,00
K1+ [m/kN]	0,130
K2+ [m <sup>2</sup> /kN]	4,730
K1- [m/kN]	0,130
K2- [m <sup>2</sup> /kN]	6,050

Gegevens Beplating		
Tabel van waarden		
Werkelijke stijfheid S	8230.45	kN
Vereiste stijfheid Serf	7780.11	kN
S >= Serf	Volledig Gesteund	

# Speciale Controles

## Ligger op verende bedding

Ligger gesteund door beplating – principe volgens EN 1993-1-3 art. 10.1.2

### Theorie

De gording, gesteund door een beplating, wordt vervangen door een ligger op verende bedding



c) Model purlin as laterally braced with rotationally spring restraint  $C_D$  from sheeting

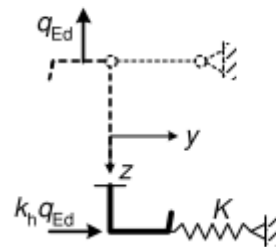

d) As a simplification replace the rotational spring  $C_D$  by a lateral spring stiffness  $K$

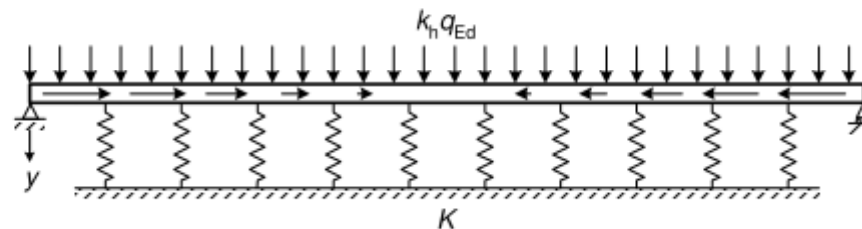

e) Free flange of purlin modelled as beam on elastic foundation. Model representing effect of torsion and lateral bending (including cross section distortion) on single span with uplift loading.

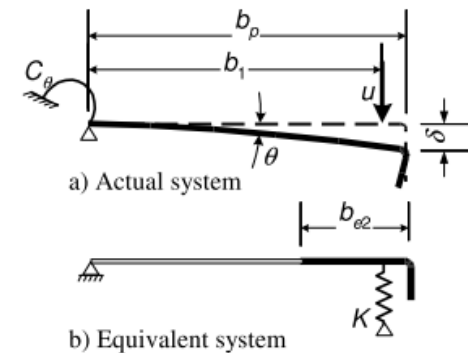

Vergelijk met de berekening van distortieknik: zelfde principe!

# Speciale Controles

## Weerstand van de doorsnede

Ligger gesteund door beplating – Weerstand van de doorsnede volgens EN 1993-1-3 art. 10.1.4.1

### Theorie

(2) The maximum stresses in the cross-section should satisfy the following:

- restrained flange:

$$\sigma_{\max,Ed} = \frac{M_{y,Ed}}{W_{\text{eff},y}} + \frac{N_{Ed}}{A_{\text{eff}}} \leq f_y / \gamma_M \quad \dots (10.3a)$$

- free flange:

$$\sigma_{\max,Ed} = \frac{M_{y,Ed}}{W_{\text{eff},y}} + \frac{N_{Ed}}{A_{\text{eff}}} + \frac{M_{fz,Ed}}{W_{fz}} \leq f_y / \gamma_M \quad \dots (10.3b)$$

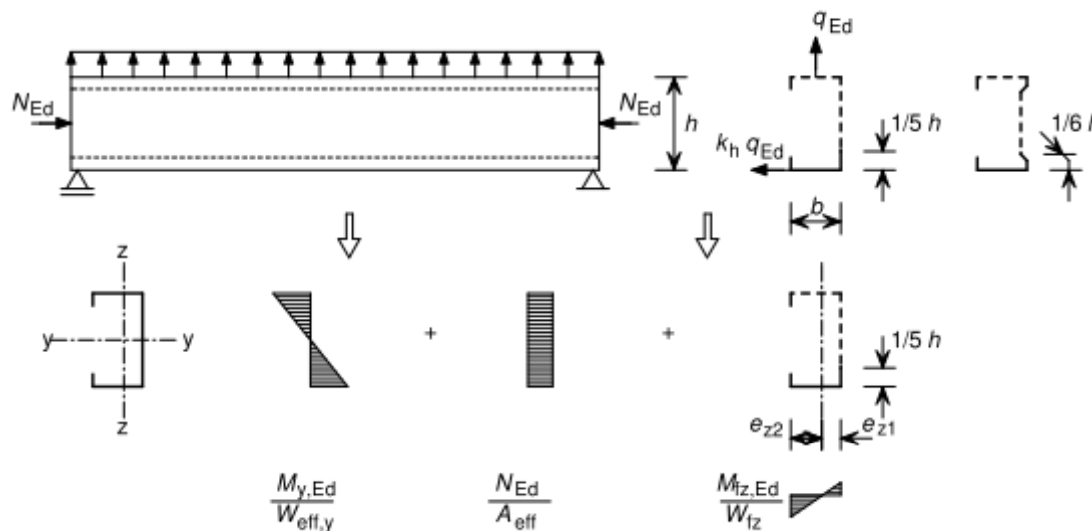

# Speciale Controles

## Weerstand van de doorsnede

Ligger gesteund door beplating – Weerstand van de doorsnede volgens EN 1993-1-3 art. 10.1.4.1

### Theorie



a) Bepaling van de geometrie van de 'vrije flens'

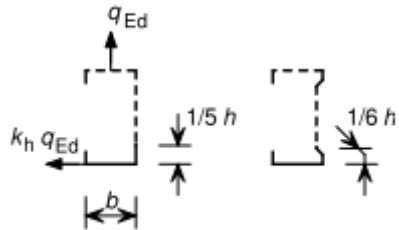

b) Bepaling van de equivalente horizontale belasting

$$q_{h,Ed} = k_h q_{Ed}$$

$$k_{h0} = \frac{I_{yz}}{I_y} \frac{g_s}{h}$$

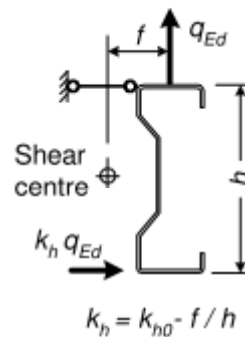

# Speciale Controles

## Weerstand van de doorsnede

Ligger gesteund door beplating – Weerstand van de doorsnede volgens EN 1993-1-3 art. 10.1.4.1

Theorie

### c) Bepaling van de laterale veerstijfheid



(4) The lateral spring stiffness  $K$  per unit length may be determined by calculation using:

$$\frac{1}{K} = \frac{4 (1 - \nu^2) h^2 (h_d + b_{\text{mod}})}{Et^3} + \frac{h^2}{C_D}$$

$$C_D = \frac{1}{(1 / C_{D,A} + 1 / C_{D,C})} \quad \dots(10.14)$$

where:

$C_{D,A}$  is the rotational stiffness of the connection between the sheeting and the purlin;

$C_{D,C}$  is the rotational stiffness corresponding to the flexural stiffness of the sheeting.

De rotatiestijfheid van de beplating kan berekend worden of volgen uit testresultaten van de fabrikant.

# Speciale Controles

## Weerstand van de doorsnede

Ligger gesteund door beplating – Weerstand van de doorsnede volgens EN 1993-1-3 art. 10.1.4.1

### Theorie

#### d) Bepaling van het equivalente buigend moment



$$M_{fz,Ed} = \kappa_R M_{0,fz,Ed} \quad \dots (10.5)$$

where:

$M_{0,fz,Ed}$  is the initial lateral bending moment in the free flange without any spring support;

$\kappa_R$  is a correction factor for the effective spring support.

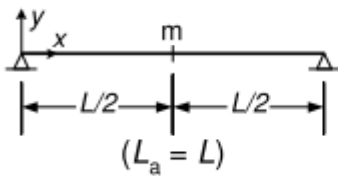
System	Location	$M_{0,fz,Ed}$	$\kappa_R$
	m	$\frac{1}{8} q_{h,Ed} L_a^2$	$\kappa_R = \frac{1 - 0,0225R}{1 + 1,013R}$

**Opmerking:** De tabel geeft slechts enkele waarden, voor een exacte berekening mag de theorie van Winkler gebruikt worden voor liggers op een verende bedding.

# Speciale Controles

## Weerstand van de doorsnede

Ligger gesteund door beplating – Weerstand van de doorsnede volgens EN 1993-1-3 art. 10.1.4.1

Scia Engineer

Berekening van de rotatiestijfheid van de beplating:

Gegevens Beplating		
Tabel van waarden		
Werkelijke stijfheid S	8230.45	kN
Vereiste stijfheid Serf	7780.11	kN
$S \geq Serf$	Volledig Gesteund	
c0Mk	307.65	kNm/m
c0Pk	6.91	kNm/m
c0Ak	1.66	kNm/m
c100	2.60	kNm/m
vorh ck	1.34	kNm/m

Geometrie van de 'vrije flens':

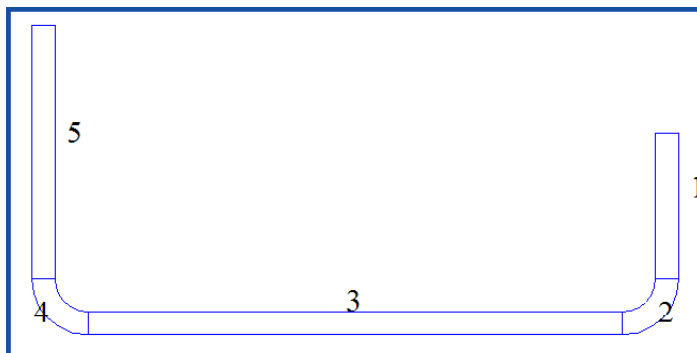

# Speciale Controles

## Weerstand van de doorsnede



Ligger gesteund door beplating – Weerstand van de doorsnede volgens EN 1993-1-3 art. 10.1.4.1

Scia Engineer



Ligger gesteund door beplating - Weerstand van de doorsnede  
Volgens artikel EN 1993-1-3: 10.1.4.1 en formule (10.3a), (10.3b).

Equivalente Laterale Last		
Verticale last qEd	4.80	kN/m
kh0	-0.00	
f	75.89	mm
h	200.00	mm
kh	-0.38	
Laterale last qh,Ed	-1.82	kN/m

Lateraal Buigend Moment		
Randvoorwaarden	Scharnierend-Scharnierend	
Mfz,Ed	-1.56	kNm

Laterale veerstijfheid		
a	40.00	mm
b	80.00	mm
hd	200.00	mm
bmod	40.00	mm
CD	1.34	kNm/m
Laterale stijfheid K	27.49	kN/m <sup>2</sup>
Ifz	3.5087e+05	mm <sup>4</sup>
La	3.000	m
R	0.31	

Tabel van waarden		
Aeff	1.1451e+03	mm <sup>2</sup>
Weff,y gesteunde flens	7.0241e+04	mm <sup>3</sup>
Weff,y vrije flens	6.7735e+04	mm <sup>3</sup>
Wfz	-7.9970e+03	mm <sup>3</sup>
Gamma M	1.00	

Eenheidscontrole (10.3a)  $(-0.20) + 0.00 = 0.20$  -  
Eenheidscontrole (10.3b)  $0.20 + 0.00 + 0.50 = 0.71$  -

# Speciale Controles

## Knikweerstand van de vrije flens

Ligger gesteund door beplating – Knikweerstand van de vrije flens volgens EN 1993-1-3 art. 10.1.4.2

### Theorie

(1) If the free flange is in compression, its buckling resistance should be verified using:

$$\frac{I}{\chi_{LT}} \left( \frac{M_{y,Ed}}{W_{eff,y}} + \frac{N_{Ed}}{A_{eff}} \right) + \frac{M_{tz,Ed}}{W_{tz}} \leq f_{yb} / \gamma_{M1} \quad \dots (10.7)$$

in which  $\chi_{LT}$  is the reduction factor for lateral torsional buckling (flexural buckling of the free flange).

**NOTE:** The use of the  $\chi_{LT}$ -value may be chosen in the National Annex. The use of EN 1993-1-1, 6.3.2.3 using buckling curve b ( $\alpha_{LT} = 0,34$  ;  $\bar{\lambda}_{LT,0} = 0,4$  ;  $\beta = 0,75$ ) is recommended for the relative slenderness  $\bar{\lambda}_{tz}$  given in (2).

**Opgelet:** de methode voor  $\chi_{LT}$  betreft een Nationaal Bepaalde Parameter !

Britse Nationale Bijlage:

The reduction factor for lateral-torsional buckling,  $\chi_{LT}$  should be obtained from BS EN 1993-1-1, 6.3.2.2 using buckling curve b.

Oostenrijkse Nationale Bijlage:

Der Abminderungsbeiwert  $\chi_{LT}$  wird unter Anwendung der ÖNORM EN 1993-1-1:2006, Abschnitt 6.3.2.3 bestimmt. Dabei wird die in der ÖNORM EN 1993-1-3:2007, Tabelle 6.3 für das Knicken um die z-z-Achse angegebene Knicklinie zugrunde gelegt (auch gemäß 5.3.2.2).

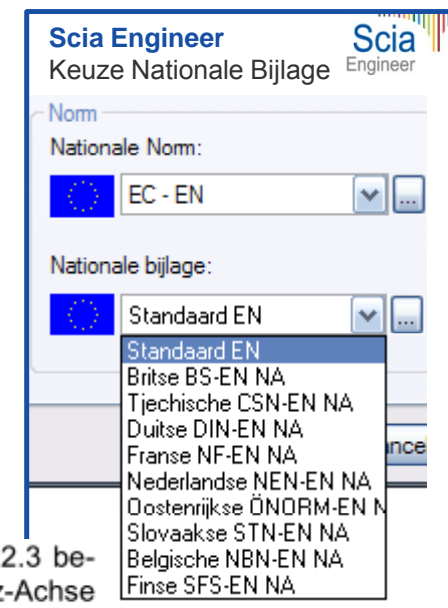

# Speciale Controles

## Knikweerstand van de vrije flens

Ligger gesteund door beplating – Knikweerstand van de vrije flens volgens EN 1993-1-3 art. 10.1.4.2

### Theorie

(2) The relative slenderness  $\bar{\lambda}_{fz}$  for flexural buckling of the free flange should be determined from:

$$\bar{\lambda}_{fz} = \frac{l_{fz} / i_{fz}}{\lambda_1} \quad \dots (10.8)$$

with:

$$\lambda_1 = \pi \left[ E / f_{yb} \right]^{0.5}$$

$$l_{fz} = \eta_1 L_a \left( 1 + \eta_2 R^{\eta_3} \right)^{\eta_4}$$

Table 10.2b : Coefficients  $\eta_i$  for uplift load with 0, 1, 2, 3, 4 anti-sag bars

Situation	Anti sag-bar Number	$\eta_1$	$\eta_2$	$\eta_3$	$\eta_4$
Simple span	0	0.694	5.45	1.27	-0.168
End span		0.515	1.26	0.868	-0.242
Intermediate span		0.306	0.232	0.742	-0.279



# Speciale Controles

## Knikweerstand van de vrije flens



Ligger gesteund door beplating – Knikweerstand van de vrije flens volgens EN 1993-1-3 art. 10.1.4.2

Scia Engineer



### Ligger gesteund door beplating - Knikweerstand van de vrije flens

Volgens artikel EN 1993-1-3: 10.1.4.2 Tabel 10.2b en formule (10.7).  
Volgens artikel EN 1993-1-1: 6.3.2.3.

Kniklengte		
La	3.000	m
R	0.31	
Eta 1	0.69	
Eta 2	5.45	
Eta 3	1.27	
Eta 4	-0.17	
Kniklengte Ifz	1.819	m
ifz	2.9887e+01	mm
Gereduceerde slankheid Lambda,fz	0.83	

Knikfactor (omega buc)		
Limiet slankheid Lambda,LT,0	0.40	
Kip curve	b	
Imperfectie Alpha,LT	0.34	
Reductie factor Chi,LT	0.80	
Eenheidscontrole	0.76	-

## Overzicht

### Rekenmodel en Uitgangspunten

Mag EN 1993-1-3 worden toegepast?

### Berekening van de Effectieve Doorsnede

Bepaling van de notionele breedte

Lokaal plooiën van de elementen onder druk

Distortieknik van de verstijvers met optionele iteraties

### Standaard UGT Controles (Niet specifiek voor gordingen)

Controle op Buiging

Controle op Dwarskracht

Controle op Lokale Dwarse Krachten

Interactie Moment en Lokale Dwarse Kracht

### Speciale UGT Controles (Specifiek voor gordingen)

Ligger gesteund door beplating  $>$   $<$  op verende bedding

Weerstand van de doorsnede

Knikweerstand van de vrije flens

# Overige mogelijkheden

Scia Engineer



## Willekeurige doorsneden

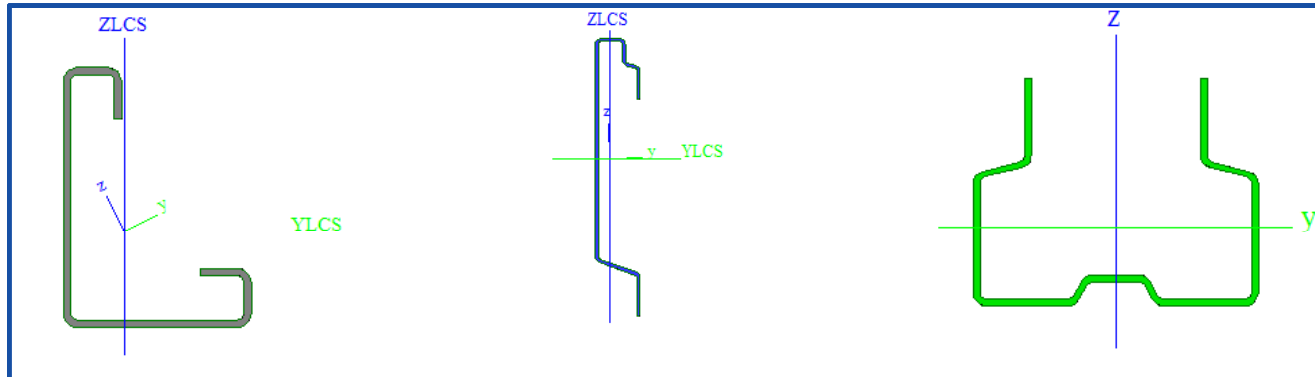

## Geavanceerde methode: Invoer Kritische Spanningen

Id	As [mm <sup>2</sup> ]	Is [mm <sup>4</sup> ]	Sigma <sub>cr,d</sub> [N/mm <sup>2</sup> ]	lambda <sub>d</sub> [-]	Chi <sub>d</sub> [-]	As,red [mm <sup>2</sup> ]
1	5,3168e+02	1,3032e+05	120,000	1,708	0,386	2,0547e+02
6	6,3282e+02	1,4647e+05	120,000	1,708	0,386	2,4456e+02

Opmerking: De kritische spanning voor distortieknik Sigma<sub>cr,d</sub> werd manueel ingegeven door de gebruiker.

## Specifieke berekeningsopties

Gebruik Lambda<sub>p,red</sub> 4.4(4)     Gebruik Annex E E. 1(1)



# Contact

Thank you for your attention



Nemetschek Scia  
Industrieweg 1007  
3540 Herk-de-Stad  
Belgium

E-Mail: [info@scia-online.com](mailto:info@scia-online.com)

Internet: [www.scia-online.com](http://www.scia-online.com)



Ask for a Presentation  
or a Tryout Edition